

- SECTION 278 WORKS:**
- All works to be carried out strictly in accordance with the Local Authority Highways specification for street works.
 - All Statutory Undertakers, including cable television companies, must be contacted prior to commencing any works to ascertain the location and depth of their apparatus. In the event of any protection or diversionary works being necessary to their apparatus then any costs incurred will be the contractors responsibility both for arranging and any payment.
 - The Contractor shall provide, erect and maintain such traffic signs, lamps, barriers and traffic control signals, and such measures may be necessitated by the construction of the works in accordance with the recommendations contained in Chapter 8 of the Traffic Signs Manual.
 - The developer and contractor shall confirm they are working in accordance with NUG Volume 1 Guidelines on the Positioning and Colour Coding of Underground Utilities Apparatus and Volume 2 Guidelines on the Positioning of Underground Utilities Apparatus for New Development Sites.
 - Root barrier to be installed at the back of the adopted footpath to prevent the roots from any proposed new trees undermining the footpath.
 - Retention of the existing kerbline will be subject to inspection and approval by the Local Authority Highways Inspector.
 - Reuse of the existing kerb race will be subject to inspection and approval by the Local Authority Highways Inspector. Reconstruction of the existing channel line to have 300mm overlap of each bituminous layer that is disturbed.
 - 150mm x 50mm back edging kerbs will be laid upturned and flush at footway crossovers.
 - Tactile paving at uncontrolled crossing points to be 400x400mm buff colour blister paving in accordance with DETR guidance on the use of paving surfaces.
 - All substrate structures and unconsolidated material within the construction width of the highway, are to be removed.
 - CBR values and calculations may be required to determine sub-base thickness.
 - Hinged gully grate and frame to BS EN 124, Grade D400, non-sloping, with captive left hand and hinge. Minimum waterway area 900cm squared. Frame depth 100mm. Black coated ductile iron.
 - All gully and channel grating in shared surfaces and footways to be pedestrian friendly.
 - Any existing gullies that are damaged during construction will be replaced with new ones, as agreed with a representative of the Local Authority Highways department.
 - Hand laying of bituminous materials is not permitted on adoptable carriageway.
 - Tarmac road construction to comply with BS EN 130108.
 - The provision of a CCTV survey of any highway drainage, at the developers expense, is required prior to laying the wearing course.
 - Where two or more water services boundary boxes are situated together multi-meter boundary as specified by the Sewerage Undertaker are to be installed.
 - A Covenant will be provided to the benefit of the Local Authority ensuring that no planting or structure greater than 6000mm in height to be permanently situated within the visibility splay.

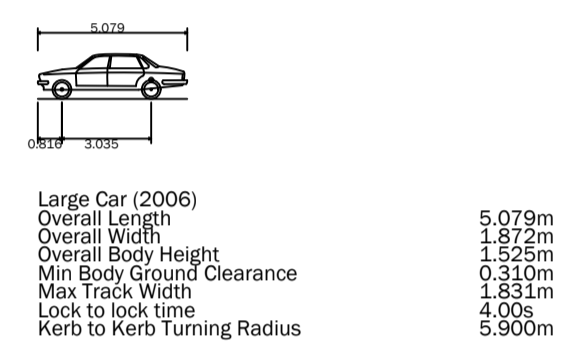

REV	DATE	REVISION NOTE	BY
P2	19-09-17	Splitter island added to A521	DMcC
P1	27.07.17	Issued for planning	AT



Seven House, 18 High Street, Longbridge, Birmingham B31 2UG, Tel: 0121 516 5154
CLIENT

St. Modwen Homes
PROJECT
Land Off A521 & A50
Blythe Bridge
Stoke-on-Trent

DRAWING TITLE
Swept Path Analysis
Large Car
Sheet 2

DRAWING ISSUE STATUS
Planning

JOB CODE STAGE DRAWING NO. REVISION
02523 - A - 0702 - P2
Revision State : P - Prelim / T - Tender / C - Construction
CLIENT REF

SCALE DESIGNED CHECKED DATE
A1@ 1:500 PAS DMcC 12/06/17